



MINISTRY OF  
SCIENCE  
AND  
INNOVATION



EDUARDO  
TORROJA  
INSTITUTE

EDUARDO TORROJA INSTITUTE FOR  
CONSTRUCTION SCIENCE  
C/ Serrano Galvache nº 4 28033 Madrid  
TEL (+34) 91 3020440 Fax: (+34) 913020700  
<http://www.ietcc.csic.es>

DIT

## TECHNICAL SUITABILITY DOCUMENT (DIT): No. 527/09

**Generic Area / Planned Use**

**VENTILATED FAÇADE  
CLADDING SYSTEM WITH  
CERAMIC PANELS**

**Trade name**

**FRONTEK PLUS**

**Recipient**

**GRECO GRES INTERNACIONAL, S.L.**

**Head office  
Location of manufacture**

Avda. Castilla La Mancha, 1  
45240 ALAMEDA DE LA SAGRA (Toledo)  
SPAIN  
Tel. (+34) 925 50 05 39 Fax: (+34) 925 50 02 70  
E-mail: [informacion@grecogres.com](mailto:informacion@grecogres.com)  
<http://www.grecogres.com>

**Validity. From:  
To:**

May 21, 2009  
May 21, 2014  
(Subject to annual follow-up)

**This document consists of 26 pages**



MEMBER OF:

**UNIÓN EUROPEA PARA LA EVALUACIÓN DE LA IDONEIDAD TÉCNICA**  
*UNION EUROPÉENNE POUR L'AGRÉMENT TECHNIQUE DANS LA*  
**CONSTRUCTION**  
*EUROPEAN UNION OF AGREEMENT*  
*EUROPAISCHE UNION FÜR DAS AGREEMENT IN BAUWESEN*

**NOELIA REDONDO JIMÉNEZ**  
C/ Padre Llanos, 2 - 5º B  
28053 MADRID  
Teléf. 647 731 429  
INTÉRPRETE JURADO INGLÉS

## VERY IMPORTANT

*By definition, THIS TECHNICAL SUITABILITY DOCUMENT constitutes a positive technical evaluation by the Eduardo Torroja Institute for Construction Science of the suitability of using non-traditional materials, systems and procedures in construction for a particular and specific use. In and of itself, it has no executive effect, nor does it represent authorization for use or a guarantee.*

*Before using the material, system or procedure under discussion, it is necessary to be aware of the whole document. Consequently, it must be supplied in its entirety by the holder of the same.*

*Modifying the characteristics of the products or failing to follow conditions for use, as well as the remarks of the Committee of Experts, invalidates the present technical evaluation.*

**UDC: 69.022.325  
Ventilated Façades  
Bardage  
Cladding Kit**

### DECISION NO. 527/09

THE DIRECTOR OF THE EDUARDO TORROJA INSTITUTE FOR CONSTRUCTION SCIENCE,

- by virtue of Decree no. 3652/1963, of December 26, of the Prime Minister, authorizing the Eduardo Torroja Institute for Construction Science (IETcc in the Spanish acronym), to issue the TECHNICAL SUITABILITY DOCUMENT (DIT in the Spanish acronym) for non-traditional construction materials, systems and procedures utilized in building and public works, and Order no. 1265/1988, of December 23, of the Ministry of Parliamentary Affairs and the Government Office, regulating awarding of the same,

- whereas, article 5.2, section 5, of the Technical Building Code (hereinafter CTE, the Spanish acronym) on compliance with the CTE for innovative products, equipment and systems, stipulates that a construction system is in compliance with the CTE if it has obtained a positive technical evaluation of its suitability for the planned use,

- in consideration of the specifications established in Regulations for Follow-up of the Technical Suitability Document, of October 28, 1998,

- in consideration of the request submitted by the company GRECO GRES INTERNACIONAL, S.L. that a TECHNICAL SUITABILITY DOCUMENT be awarded for the **FRONTEK PLUS ventilated façade cladding system with ceramic panels**,

- by virtue of current statutes of the Union Européenne pour l'Agrément technique dans la construction (UEAtc),

- taking into consideration the reports from on-site visits carried out by representatives of the Eduardo Torroja Institute for Construction Science, reports on the tests carried out at the IETcc, as well as the remarks made by the Committee of Experts at a meeting held on April 21, 2009,

### DECIDES:

To award TECHNICAL SUITABILITY DOCUMENT number 527/09 to the **FRONTEK PLUS ventilated façade cladding system with ceramic panels**, in consideration of the fact that,

**The technical evaluation carried out makes it possible to conclude that the system is in COMPLIANCE WITH THE TECHNICAL BUILDING CODE, provided that the contents of the entire present document are respected, particularly the following terms and conditions:**

### GENERAL TERMS AND CONDITIONS

The present Technical Suitability Document evaluates only the construction system submitted by the applicant. In accordance with current regulations, in each case, this must be accompanied by the mandatory construction plan and be carried out with the necessary project management. In each case, it shall be the construction plan which discusses the actions which the system transfers to the overall structure of the building, ensuring that these are admissible.

**NOELIA REDONDO JIMÉNEZ**  
C/ Padre Llanos, 2 - 5º B  
28053 MADRID  
Teléf. 647 731 429  
INTÉRPRETE JURADO INGLÉS

*Noelia Redondo Jiménez*

In each case, GRECO GRES INTERNACIONAL, S.L., in view of the architectural design for the façade prepared by the architect who drew up the plans, will provide the graphic definition of the ventilated façade plans from the technical point of view and sufficient technical support (submission of this technical suitability document at least) to make it possible to perform calculations and definitions for execution, including all of the necessary information on each one of the components.

In each case, the technical plans for the ventilated façade must be accompanied by a calculation log providing evidence of the system's suitable performance in response to anticipated actions.

In general, all requirements contained in current regulations shall be taken into account in both the plans and execution of the work.

#### **MANUFACTURING AND INSPECTION CONDITIONS**

The manufacturer must continue the self-inspection it currently performs on raw materials, the manufacturing process and the finished product, in accordance with the instructions given in section 5 of the present document.

#### **CONDITIONS OF USE AND INSTALLATION**

The FRONTEK PLUS ventilated façade cladding system with ceramic panels evaluated in the present document is intended to clad façades by means of a concealed mechanical fixing system attached to a metal sub-structure using clamps.

The system must be installed by GRECO GRES INTERNACIONAL, S.L., or by specialized and qualified companies recognized by the recipient, with the technical support of the same. These companies shall guarantee that installation of the system is carried out under the conditions and scope of application covered by the present document, taking note of the remarks made by the Committee of Experts. A copy of the updated list of installer companies recognized by GRECO GRES INTERNACIONAL, S.L. will be available at the IETcc.

All of the necessary requirements will be adopted relative to the stability of the structure during assembly, the risk of falling suspended loads, and personal protection. Generally speaking, the requirements contained in current occupational health and safety regulations will be taken in account.

#### **VALIDITY**

The present Technical Suitability Document number 527/09 is valid for a period of five years, subject to the following conditions:

- that the manufacturer not modify any of the characteristics of the product as indicated in the present Technical Suitability Document,
- that the manufacturer carry out systematic self-monitoring of production, as indicated in the Technical Report,
- that on an annual basis, the Institute perform a follow-up to verify compliance with the above conditions, visiting one of the sites completed, should it be deemed appropriate.

With the positive result of the follow-up, the IETcc will issue an annual certificate which must accompany the Technical Suitability Document in order for it to be valid.

This document must therefore be renewed prior to May 21, 2014.

Madrid, May 21, 2009

THE DIRECTOR OF THE EDUARDO TORROJA  
INSTITUTE FOR CONSTRUCTION SCIENCE

Carlos Miravittles Torras

NOELIA REDONDO JIMÉNEZ  
C/ Padre Llanos, 2 - 5º B  
28053 MADRID  
Teléf. 647 731 429  
INTÉRPRETE JURADO INGLÉS

## TECHNICAL REPORT

### 1. OBJECT

The system known by the trade name FRONTEK PLUS is intended for use as cladding for ventilated façades on newly-built or renovated buildings. It is made from "extruded porcelain" ceramic panels by the company VENATTO DESIGN, S.L., fixed to an aluminum sub-structure by means of a concealed mechanical fixing system (clamps).

The sub-structure consists of vertical aluminum profiles, adjustable brackets and the corresponding fasteners, designed to be attached to flat, vertical facings made of brick, stone or concrete, or to a metal framework (see figure 1).

The fasteners fixing the sub-structure to the substrate and the thermal insulation do not form part of the system, and therefore they have not been evaluated. In any case, the fasteners must be defined in the technical plans for the ventilated façade depending on the substrate and the loads to be transferred.

### 2. PRINCIPLE AND DESCRIPTION OF THE SYSTEM

The FRONTEK PLUS cladding system for façades with ceramic panels by VENATTO DESIGN, S.L., is made up of (see figure 1):

- Exterior cladding of "extruded porcelain" ceramic panels supplied by VENATTO DESIGN, S.L.
- Ventilated air chamber in which thermal insulation not supplied by the recipient is normally installed.
- Load-bearing sub-structure fixed to the substrate. This sub-structure, supplied by GRECO GRES INTERNACIONAL, S.L., is made up of:
  - Aluminum brackets to transfer loads from the sub-structure to the substrate by means of fasteners.
  - Vertical sub-structure of aluminum profiles.
  - Concealed mechanical fixing system using stainless steel clamps.
- Fasteners from the brackets to the substrate.
- Accessories for handling unique points.

### 3. MATERIALS AND COMPONENTS

#### 3.1 Panels

These are extrusion-molded ceramic panels (see figure 6).

##### 3.1.1 Characteristics

The panels are classified as extruded tiles with low water absorption (A1) according to the UNE-EN 14411<sup>(1)</sup> standard, with the following characteristics, as stated by the manufacturer:

Table 1. PANELS		
Classification		
Method of manufacture	Extrusion (Group A)	
Water Absorption (E)	≤ 3% (Group A1)	
Dimensional properties		
Length & width	± 0.2 *	%
Thickness	± 7.0 *	%
Straightness of sides	± 0.2 *	%
Rectangularity	± 0.4 *	%
Surface flatness	± 0.2 *	%
Physical properties		
Apparent density	≈ 2.3	g/cm <sup>3</sup>
Water absorption	≤ 0.5	% (of weight)
Reaction to fire	A1 **	
Flexural strength	≥ 25 *	MPa
Coefficient of linear thermal expansion	≤ 5·10 <sup>-6</sup>	K <sup>-1</sup>

\* Higher than required by the standard.

\*\* According to Commission Decision 96/603/EC of October 4, 1996, establishing the list of products classified as class A (no contribution to fire).

##### 3.1.2 Dimensional properties

The standard manufacturing dimensions for the panels are defined in Table 2 and figure 6:

Table 2. STANDARD DIMENSIONS				
Size (nom. mm)	Length (mm)	Height (mm)	Thickness (mm)	Weight (kg)
405 x 600	600	405	≈ 19.5	≈ 7.5
405 x 800	800	405	≈ 19.5	≈ 10.0
405 x 900	900	405	≈ 19.5	≈ 11.25
405 x 1000	1000	405	≈ 19.5	≈ 12.5

It is possible to supply smaller sized panels than these, with the same thicknesses and tolerances, provided that stresses due to the action of the wind under which the panels are operating are less than those defined in this document.

(1) UNE-EN 14411: Ceramic tiles. Definitions, classification, characteristics and marking.

### 3.2 Sub-structure for fixing the panels

#### 3.2.1 Materials

##### a) Aluminum

The framework of vertical profiles and brackets is made of extruded aluminum, an aluminum-magnesium-silicon alloy EN AW-ALMgSi (6063) with T5 treatment. Its basic characteristics are shown in Table 3.

Designation	
Symbol	EN AW-Al MgSi
Number	AW 6063
Treatment	T5
Standard	UNE-EN 755-2 <sup>(2)</sup> UNE-EN 12020-1 <sup>(3)</sup>
Physical properties	
Specific weight	2.70 g/cm <sup>3</sup>
Coefficient of linear thermal expansion	23.6·10 <sup>-6</sup> K <sup>-1</sup> (20/100°C)
Modulus of elasticity	69,500 MPa
Poisson's ratio	0.33
Mechanical properties	
Tensile strength (R <sub>m</sub> )	≥ 175 N/mm <sup>2</sup>
Yield strength (R <sub>p0.2</sub> )	≥ 130 N/mm <sup>2</sup>
Elongation (A)	≥ 8%

##### b) Stainless steel

The clamps fixing the panels to the sub-structure are AISI 304 stainless steel. Their basic characteristics are shown in Table 4.

Designation	
ASTM	AISI 304
Number	1.4301
Symbol	X5CrNi18-10
Standard	UNE-EN 10088-2 <sup>(4)</sup>
Physical properties	
Specific weight	7.93 g/cm <sup>3</sup>
Coefficient of linear thermal expansion	17.3·10 <sup>-6</sup> K <sup>-1</sup> (20/100°C)
Modulus of elasticity	190,000 MPa
Poisson's ratio	0.33
Mechanical properties	
Tensile strength (R <sub>m</sub> )	540 - 750 N/mm <sup>2</sup>
Yield strength (R <sub>p0.2</sub> )	≥ 230 N/mm <sup>2</sup>
Elongation (A)	45%
Brinell hardness	183

<sup>(2)</sup> UNE-EN 755-2: Aluminum and aluminum alloys. Extruded rod/bar, tube and profiles. Part 2: Mechanical properties.

<sup>(3)</sup> UNE-EN 12021-1: Aluminum and aluminum alloys. Extruded precision profiles in EN AW-6060 AND EN AW-6063 alloys. Part 1: Technical conditions for inspection and delivery.

<sup>(4)</sup> UNE-EN 10088-2: Stainless steels. Part 2: Technical delivery conditions for sheet/plate and strip of corrosion resisting steels for general purposes.

NOELIA REDONDO JIMÉNEZ  
C/ Padre Llanos, 2 - 5º B  
28053 MADRID  
Teléf. 847 731 429  
INTÉRPRETE JURADO INGLÉS

*Noelia Redondo Jiménez*

### 3.2.2 Vertical profiles

The sub-structure of vertical profiles is made up of extruded aluminum profiles (6063 T5) with a T-section and a thickness of approximately 2 mm (see figure 3). The properties of the aluminum are described in section 3.2.1.

Table 5 shows the geometrical and mechanical properties of the most representative vertical profile. Tolerances are according to the UNE-EN 755-9 standard.<sup>(5)</sup>

PROFILE		Section (mm <sup>2</sup> )	Perimeter (mm)	Weight (kg/ml)	x <sub>c</sub> (mm)	I <sub>xc</sub> (cm <sup>4</sup> )	r <sub>xc</sub> (mm)	y <sub>c</sub> (mm)	I <sub>yc</sub> (cm <sup>4</sup> )	r <sub>yc</sub> (mm)
60 x 100 T profile	T	290.48	357.39	0.783	50	9.55	18.13	47.00	14.27	22.17

The geometry and dimensions of the vertical profile are shown in figure 3.

NOELIA REDONDO JIMÉNEZ  
C/ Padre Llanos, 2 - 5º B  
28053 MADRID  
Teléf. 647 731 429  
INTÉRPRETE JURADO INGLÉS

<sup>(5)</sup> UNE-EN 755-9: Aluminum and aluminum alloys. Extruded bar, tube and profiles. Part 9: Profiles, tolerances on dimensions and form.

### 3.2.3 Brackets

Extruded aluminum (6063 T5) adjustable brackets with an approximate thickness of 3 mm (see figure 5) are used to fix the vertical profiles to the substrate. The properties of the aluminum are described in section 3.2.1.

Table 6 shows the geometrical and mechanical properties of a selection of brackets.

ITEM	Section (mm <sup>2</sup> )	Perimeter (mm)	x <sub>c</sub> (mm)	I <sub>xc</sub> (cm <sup>4</sup> )	r <sub>xc</sub> (mm)	y <sub>c</sub> (mm)	I <sub>yc</sub> (cm <sup>4</sup> )	r <sub>yc</sub> (mm)
ECI 108-60 / 100-60 / 102-60 / 104-60	321	220	37.5	11.83	19.2	17.48	7.55	15.33
ECI 108-80 / 100-80 / 102-80 / 104-80	381	260	39.2	25.97	26.1	25.8	8.16	14.6
ECI 108-100 / 100-100 / 102-100 / 104-100	441	300	40.5	47.57	32.8	34.5	8.61	13.9
ECI 108-120 / 100-120 / 102-120 / 104-120	501	340	41.5	77.88	39.4	43.5	8.95	13.4

The geometry and dimensions of two of the most representative brackets are shown in figure 5, to serve as an example.

### 3.2.4 Clamps for fixing the ceramic panels

The clamps for concealed mechanical fixing of the panels to the vertical profiles are AISI 304 stainless steel with a general thickness of 1 mm ( $\pm 0.05$ ). The properties of the stainless steel are described in section 3.2.1.

The dimensional characteristics of the clamps are shown in figure 4.

### 3.3 Screws

A2 stainless steel DIN 7504 K<sup>(6)</sup> hexagon head self-drilling screws,  $\varnothing$  5.5 and L = 22 mm, are used to fix the vertical profile to the brackets. See Table 7.

Description	Hexagon head self-drilling screw
Standard	DIN 7504 K UNE-EN ISO 15480 <sup>(7)</sup>
Nominal diameter	5.5 mm
Length	22 mm
Material	A2 austenitic stainless steel (AISI 304)
Standard	EN-ISO 3506-1 <sup>(8)</sup>
Resistance class	70
Tensile strength (R <sub>m</sub> )	700 MPa

<sup>(6)</sup> DIN 7504-K: Hexagon head self-drilling screws.

<sup>(7)</sup> EN ISO 15480 Hexagon washer head drilling screws with tapping screw thread (ISO 15480:1999)

<sup>(8)</sup> EN ISO 3506-1: Mechanical properties of corrosion-resistant stainless steel fasteners Part 1: Bolts, screws and studs.

Tolerances are according to the UNE-EN 755-9 standard.<sup>(5)</sup>

There are two types of brackets:

- Support brackets, which bear the wind loads and the weight of the system itself.
- Retaining brackets, which only bear wind loads.

Yield strength (R <sub>p0.2</sub> )	450 MPa
Elongation at fracture (%)	$\geq 0.4d$
Torque (N-m)	4.1

A2 stainless steel (ETANCO DXP361 or equivalent) flat head self-drilling screws,  $\varnothing$  4.2 and L = 14 mm, are used to fix the clamps to the vertical profiles. See Table 8.

Description	Flat head self-drilling screw
Type	ETANCO DXP361
Nominal diameter	4.2 mm
Length	14 mm
Material	A2 austenitic stainless steel (AISI 304)
Standard	EN-ISO 3506-1 <sup>(8)</sup>
Resistance class	50
Tensile strength (R <sub>m</sub> )	500 MPa
Yield strength (R <sub>p0.2</sub> )	210 MPa
Elongation at fracture (%)	$\geq 0.6d$
Torque (N-m)	2.0

The screwdriver must be used with depth and torque control. Turning speed of 1,800-2,500 min<sup>-1</sup>, with an axial strength of 250 N (UNE-EN ISO 10666<sup>(9)</sup>).

<sup>(9)</sup> UNE-EN ISO: 10666: Drilling screws with tapping screw thread - Mechanical and functional properties.

### 3.4 Fasteners at the joining with the substrate

The type, position and number of fasteners to fix the brackets to the substrate are defined based on the supporting base and the stresses transferred to it. This must be shown in the technical plans for the ventilated façade.

This information will be supplied by the party responsible for the system, depending on the recommendations of the manufacturer of the fasteners attached to the substrate for each supporting base material.

It is the responsibility of the installing company and the site manager to verify that the fasteners defined in the technical plans are suitable for the supporting element on site.

### 3.5 Polyurethane sealant

A line of sealant is applied between the vertical T-profiles and the ceramic panels to achieve a flat final surface and prevent the panels from "banging".

A single-component polyurethane sealant similar or equivalent to Sista Solyplast SP-101 is used, with the following properties:

Description	Single-component polyurethane sealant
Type	Sista Solyplast SP-101
Density	1.37 g/ml
Hardness	53 Shore
Modulus of elasticity	1.60 N/mm <sup>2</sup> (NF-P8506)
Elongation at fracture	300% (NF-P8557)
Adhesion	> 1 MPa
Temperature resistance	-30°C to + 90°C
Skin formation	30-40 minutes
Curing time	2-3 mm/24 hours

The tests included in section 10 of the present document were carried out for panels fixed without the polyurethane sealant.

## 4. MANUFACTURE

### 4.1 Ceramic panels

The manufacturing process for the ceramic panels takes place at the VENATTO DESIGN, S.L. factory in Alameda de la Sagra (Toledo) and generally includes the following successive stages:

- Batching, mixing and wet grinding of the raw materials that will make up the medium for the ceramic panel.

- Atomization of part of the product of the grinding process to form the powder for mixing.
- Blending and mixing of the ground product, atomized powder and if appropriate, calcined oxides (pigments).
- Flat extrusion to form the panel.
- Drying.
- Enameling (depending on the model).
- Baking.
- Machining (straightening and beveling).
- Classification.
- Machining (grooving and meshing).
- Packing and storage prior to shipping.

### 4.2 Metal sub-structure

Manufacture of the profiles is carried out by aluminum profile extrusion and shaping companies, which ensure that they have the required quality and uniformity.

## 5. QUALITY CONTROL

### 5.1 Ceramic panels

VENATTO DESIGN, S.L. has an on-site production control system at its Toledo factory.

The frequency of internal inspections of raw materials, manufacturing procedures and finished product are established in the Factory Production Inspection Manual, of which the IETcc is aware.

#### 5.1.1 Raw materials

The suppliers of each raw material provide a certificate with the mechanical and chemical properties that define the product in accordance with the specifications and technical data sheet required by the manufacturer of the panels.

Additionally, the manufacturer performs the following inspections upon receipt of raw materials:

- Sampling and determination of the physical properties of raw materials upon receipt: visual appearance, moisture (%), rejection, chemical analysis, presence of carbonates and calcination loss.

NOELIA REDONDO JIMÉNEZ  
C/ Padre Llanos. 2 - 5º B  
28053 MADRID  
Teléf. 647 731 429  
INTERPRETE JURADO INGLÉS



### 5.1.2 Processes

Process	Control
Preparation of pastes	Moisture control of raw materials, control of the loading volume of the grinding material, density and viscosity of the ceramic slip from the wet grinding, rejection, moisture control during atomizing, temperature control of the drying gases in the atomizer.
Extrusion	Extrusion pressure, vacuum control for the extruder, deviation from rectangularity and size control.
Enameling	Density and viscosity of the enamel. Application weight.
Baking	Temperature control, atmosphere of the gases inside the ovens during the baking cycle. Size and apparent density control when removed from the oven.
Machining	Dimension control upon completion of the machining process.
Classification	Surface appearance control, determination of size deviations in terms of length and width, rectangularity, straightness of sides, surface flatness and warping.

### 5.1.3 Finished products

Inspection of 100% of the size and surface properties of the panels and sampling to determine the physical and chemical properties of the item, specified below:

Property	Control
Physical properties	Water absorption (%)
	Flexural strength (N/mm <sup>2</sup> )
	Resistance to deep abrasion
	Surface scratch resistance (Mohs scale)
	Resistance to surface abrasion for enamels
	Resistance to thermal shock
	Determination of linear thermal expansion
	Determination of moisture expansion
	Crazing resistance (on enamels)
	Determination of absolute and apparent density
Chemical properties	Frost resistance
	Resistance to stains for enameled products
	Resistance to household chemicals and pool cleaning salts
	Resistance to acids and alkalis

All controls and inspections are periodically collected in logbooks as determined by quality management system procedures. Tests on finished products are carried out as stipulated by the UNE-EN ISO 10545 standard.

### 5.2 Sub-structure

These elements are not manufactured by GRECO GRES INTERNACIONAL, S.L. Consequently, suppliers are required to provide a certificate with each supply indicating the technical specifications and compliance with respective regulations.

The inspections which GRECO GRES INTERNACIONAL, S.L. performs on the profiles, clamps and screws upon receipt of these items are:

- General appearance and finish.
- Size.
- Checking the manufacturer's certificate with regard to the technical specifications.

### 5.3 Fasteners

The supplier of the fasteners must guarantee that the products in the fixing system have passed internal manufacturing and final product inspections, according to internal standards and procedures, as well as that all these products are in compliance with specifications for the material and load values indicated in the supplier's current manuals and catalogues, provided that they are installed according to the supplier's recommendations and instructions.

When relevant, the fasteners must bear the CE mark.

### 5.4 Sealant

An inspection of the polyurethane sealant is carried out upon receipt, requiring that suppliers provide a certificate with each supply indicating the technical specifications and compliance with respective regulations.

## 6. LABELING, PACKING, TRANSPORT, STORAGE AND HANDLING.

The panels are supplied in clearly identified cardboard boxes containing a maximum of four units. They are plastic wrapped in bundles of no more than three boxes, palletized and sheathed in plastic with heat straps.

The packaging for the panels must indicate the following as a minimum:

- Trade name of the manufacturer.
- Model and class.
- Date of manufacture and control number, which makes traceability possible.
- Nominal dimensions.
- Number of panels.

- DIT logo and number.

The ceramic panels will be positioned on the mode of transport in such a way that any movement which may damage them during transport is prevented.

The materials must be unloaded as close as possible to where they will be used, in order to prevent carrying them unnecessary distances. In order to prevent wear on the surface from contact with sharp particles, sliding the panels together should be avoided, lifting them one by one.

Impact against the materials during unloading and handling should be avoided and care should be taken not to drop them. During transport and assembly, gloves must be used to handle the materials.

## 7. ON-SITE INSTALLATION

### 7.1 General specifications

On-site installation of the system must be performed by qualified companies specializing in the assembly of ventilated façades and recognized by GRECO GRES INTERNACIONAL, S.L., with its control and technical support.

In any event, GRECO GRES INTERNACIONAL, S.L. will provide all the information necessary to carry out the project and execute the ventilated façade. If requested, it must provide technical support during the planning and execution stages, including dealing with unique points.

Assembly is carried out using the fixing devices described above, so that the panel is not subject to stress and has sufficient freedom of movement.

#### 7.1.1 Fixing system

The fixing system must anticipate the expansion of the panels and must be defined depending on:

- Wind loads.
- Maximum distances between mounting points for the panels.
- Format of the panels.

#### 7.1.2 Ventilation

The existence of a continuous air chamber behind the cladding with a width of between three and ten centimeters, ventilated by vertical natural convection must be taken into account.

The total effective area of the ventilation openings will be 120 cm<sup>2</sup> for every 10 m<sup>2</sup> of façade between slabs, distributed 50-50 between the upper and lower part. The joints between panels can be included in the calculation for these purposes.

#### 7.1.3 Fasteners

The fasteners fixing the sub-structure to the substrate do not form part of the system, and they have therefore not been evaluated. However, the type, position and number of fasteners must be defined in the technical plans for the ventilated façade depending on the type and condition of the substrate and the loads transferred to it.

On site, it is necessary to check the type and condition of the substrate, as well as whether the fasteners indicated in the technical plans are suitable for the same. In the event that the planned fasteners are not adequate, they must be replaced, with the approval of the site manager, taking any necessary precautions with regard to position and number of fasteners.

### 7.2 Assembly

The sequence of operations for installation will be as follows:

- Layout.
- Installation of brackets.
- Installation of profiles.
- Installation of the insulation, if appropriate.
- Installation of the end clamps on the lower edge of the façade.
- Successive installation of panels and clamps, establishing joints and applying sealant.

#### 7.2.1 Layout

The façade will be laid out, checking the evenness of the substrate to be clad, verifying the flatness for a proper fastener choice.

The axis of the vertical profiles will be placed depending on the dimensions of the cladding panels, at a distance equal to or less than 105 cm, depending on the format of the panel, according to what is defined in the plans and justified by calculations.

The characteristics of the substrate, for both overhang and flatness, must comply with the conditions established in the CTE, as well as the relevant current standards and regulations.

NOELIA REDONDO JIMÉNEZ  
C/ Padre Llanos, 2 - 5º B  
28053 MADRID  
Teléf. 647 731 429  
INTÉRPRETE JURADO INGLÉS

*[Handwritten signature]*

### 7.2.2 Installation of brackets

First, the brackets will be fixed to the supporting wall or girders and/or edges of the slab using suitable fasteners.

The brackets will be installed, aligned vertically, distributed between the edges of the slab. The vertical distance will depend on the type and condition of the substrate as well as the loads to be transferred to it. Provided that the substrate so allows, this will be less than 110 cm.

There are two types of brackets:

- Supporting brackets, which bear the wind loads and the weight of the system itself. These are generally fixed to the slab edges.
- Retaining brackets, which only bear wind loads. These are generally fixed to the supporting wall.

### 7.2.3 Installation of the vertical profiles

The T-profiles will be fixed to the brackets with the screws described in section 3.4, with a distance between them equal to or less than 105 cm.

The flatness of the extruded aluminum profile structure must be guaranteed by a suitable fixing system, with the aim of ensuring that the cladding system is level.

The vertical profiles, lined up perfectly, will be fixed to the brackets with fixed mounting holes in such a way that they guarantee adequate movement of the sub-structure and proper levelness.

The minimum horizontal joint between vertical profiles will be 2 mm for each linear meter of profile.

### 7.2.4 Installation of the insulation

If applicable, the entire exterior face of the supporting wall and the resistant structure of the building will be covered according to the specifications in the plans.

### 7.2.5 Installation of the clamps and panels

The lower clamps will be installed first, screwing them to the vertical profile. A line of the sealant described in section 3.5 will be applied to the profiles on which the panel will rest.

The ceramic panel is then positioned on the lower clamps, fitting the upper arm of the clamps onto the piece. Then the upper clamps are positioned, fitting them perfectly into the upper groove. In this way the pieces will be stabilized.

The same procedure will be used on the upper levels.

### 7.2.6 Joints

The joints between panels must always be open. The vertical joint must be 3-6 mm. The horizontal joint will be 6-8 mm.

The expansion joints of the building must coincide with a vertical joint in the façade system, using a double profile. In this case, the vertical joint between ceramic panels must not be less than the width established for the expansion joint.

Likewise, a single panel must not be fixed to two different vertical profiles according to the vertical direction. The end and top clamps must be used.

## 8. SITE REFERENCES

The ceramic panels by VENATTO DESIGN, S.L. have been manufactured and installed since 2000, and the ventilated façade system since 2004.

The recipient provides the following projects implemented between 2004 and 2008 as site references:

- Nuestra Señora del Buen Consejo School in Pozuelo de Alarcón (Madrid), 1,300 m<sup>2</sup>. FRONTEK Ref. 40.5 x 80 Iceberg panel.
- Automobile dealership at C/ Calabozos in Alcobendas (Madrid), 260 m<sup>2</sup>. FRONTEK Ref. 40.5 x 80 Urban and Azabache panel.
- Dormitory at San Pablo Ceu University on Avda. Montepíncipe, Boadilla del Monte (Madrid), 650 m<sup>2</sup>. FRONTEK Ref. 40.5 x 80 Canyon and Azabache panel.
- Supercor (El Corte Inglés) in La Navata (Madrid), 840 m<sup>2</sup>. FRONTEK Ref. 40.5 x 80 Iceberg and Urban panel.
- Supercor (El Corte Inglés) in Plaza de la Asunción in Pinto (Madrid), 700 m<sup>2</sup>. FRONTEK Ref. 40.5 x 80 Iceberg panel.
- Head offices of the distribution company Perez Abenial, S.L. in Zaragoza, 470 m<sup>2</sup>. FRONTEK Ref. 40.5 x 80 Iceberg/Urban panel.
- Building for residential and business use on C/Hortensia, Zaragoza, 550 m<sup>2</sup>. FRONTEK Ref. 40.5 x 80 Iceberg panel.

NOELIA REDONDO JIMÉNEZ  
C/ Padre Llanos, 2 - 5º B  
28053 MADRID  
Teléf. 647 731 429  
INTÉRPRETE JURADO INGLÉS

- Head offices of the textile company Cordoban, on C/ Albasanz, Madrid, 300 m<sup>2</sup>. FRONTEK Ref. 40.5 x 80 Iceberg panel.

The IETcc has made various visits to the sites, as well surveying the users, all with satisfactory results.

## 9. CALCULATION LOG

The technical plans for the ventilated façade must include a calculation log which provides evidence that the system will perform adequately in response to the anticipated actions.

### 9.1 Determining actions

The actions affecting the ventilated façade system will be calculated as established in the CTE-DB-SE-AE code on Actions in Buildings, with the load increase included in the CTE-DB-SE code on Structural Safety.

In order to make the calculations for the systems, it is assumed that the ceramic panels must bear the wind load and transfer it, together with its own weight, to the substrate through the sub-structure and fasteners. The ceramic panels, fixings, sub-structure and fasteners must withstand the forces produced by the wind, as well as their own weight.

For buildings up to 30 meters high and for the limitations included in the CTE-DB-SE-AE code regarding wind action, these shall be determined as stipulated in the aforementioned Basic Document. The wind pressure/suction coefficients included in appendix D to this Basic Document (table D.1) must be used, depending on how narrow the building is and the position of the panel, taking the panel's area of influence as the general area of influence.

For greater heights and/or for those cases which go beyond the scope of application of the aforementioned Basic Document, or when the action of the wind is expected to be greater than considered in the CTE-DB-SE-AE code, it will be necessary to perform a specific study to determine the action of the wind, as well as the wind pressure/suction coefficients.

### 9.2 Parameters for calculation

The mechanical properties of the panels are described in section 3.1 of the present document. The mechanical properties of the aluminum profiles are described in section 3.2 of the present document.

The wind pressure/suction resistance values for the points where the panel is fixed to the substructure can be taken from the results of test 10.3.1, affected by the corresponding safety

coefficient. This value must be compared with the wind load obtained for the planned configuration of the façade.

The safety coefficient for the resistance values of the fixings must be specified in the technical plans for the ventilated façade. A coefficient of less than 2.5 is not recommended.

### 9.3 Calculation hypotheses

The following calculation hypotheses may be assumed:

- The actions of the wind on the panels, as well as the weight of the panels themselves, are transferred by the panels directly to the vertical profiles through the clamps used to fix the panels.
- With regard to the action of the wind, the ceramic panels shall be assumed to rest on at least four mounting points on the uprights. Their flexural strength must be verified for the anticipated action of the wind.

With regard to its own weight, the panel behaves like a beam with a long edge.

- The mounting points between the panel and the sub-structure must be capable of transferring the anticipated shear stress, depending on the tributary area corresponding to that mounting point.

### 9.4 Profiles and fixing systems between profiles

The profiles function by bending, transferring the isolated loads they receive to the supporting (vertical and horizontal loads) and retaining (horizontal loads only) brackets.

Calculations for the profiles with regard to the action of the wind will be performed using elastic methods, assuming that the joints between profiles are articulated. As there are no specific regulations, the deformation of the profiles can be limited to L/200 of the distance between points of support.

Additionally, it must be verified that the pull-out resistance of the screws for the profile thickness under consideration is sufficient to ensure transfer of the loads at the mounting points, with a suitable safety coefficient.

NOELIA REDONDO JIMÉNEZ  
C/ Padre Llanos, 2 - 5º B  
28053 MADRID  
Teléf. 647 731 429  
INTÉRPRETE JURADO INGLÉS

## 10. TESTS

The following tests have been carried out at the Eduardo Torroja Institute for Construction Science (IETcc) (Report no. 19,236.2, in accordance with the UNE-EN 14411<sup>(1)</sup> and UNE-EN ISO 10545<sup>(10)</sup> standard, EOTA Technical Report TR 001 "Determination of impact resistance of panels and panel assemblies" and the draft of the EOTA Guideline "Guideline for European Technical Approval of Kits for external wall claddings. Part 1: Ventilated cladding elements and associated fixing devices" (January 2006 edition).

### 10.1 Tests to identify the ceramic panels

#### 10.1.1 Dimensional properties

Tests carried out in accordance with the UNE-EN ISO 10545-2:1998 standard, with the values obtained being in compliance with the UNE-EN 14411:2004 standard and as stated by the manufacturer in the Technical Report.

#### 10.1.2 Apparent density and water absorption

Tests carried out in accordance with the UNE-EN 10545-3:1997 standard, with the values obtained being in compliance with the UNE-EN 14411:2004 standard and as stated by the manufacturer in the Technical Report.

#### 10.1.3 Flexural strength

Test carried out in accordance with the specifications contained in the EN 10545-4:1997 standard.

The values obtained were greater than those required by the product standard, as stated by the manufacturer in the Technical Report.

The minimum breaking stress obtained in the tests was 31.8 MPa, equivalent to 16 kN/m<sup>2</sup>\* for distances between support points of 1 meter.

For the different panel formats included in this document, a breaking stress value of 25 MPa (N/mm<sup>2</sup>) is equivalent to wind pressure of:

Length x height (mm)	Thickness (mm)	Inertia (cm <sup>4</sup> )	WP* (kN/m <sup>2</sup> )
600 x 405	19.5	23.9	33
800 x 405	19.5	23.9	19
900 x 405	19.5	23.9	15
1000 x 405	19.5	23.9	12

\* Equivalent wind pressure, without safety coefficient or load increase.

<sup>(10)</sup> Ceramic tiles.

## 10.2 Panel hardness tests

Having carried out the accelerated aging test, as described below, the breaking stress values are determined as defined in section 10.1.3.

### 10.2.1 80°C oven

The panels are left in an 80°C oven for between 28 and 56 days.

From the results of the flexural strength test, it was observed that there was no decrease in the flexural strength, in comparison with the values obtained in the reference test discussed in section 10.1.3.

### 10.2.2 Saturation and drying

The ceramic panels are subjected to the action of the following cycle, as defined in the UNE-EN 494:1995<sup>(11)</sup> standard, test 7.3.5:

- Immersion in room temperature water for 18 hours.
- Drying in a 60°C ±5°C oven for 6 hours.

From the results of the flexural strength test, it was observed that there was no decrease in the flexural strength, in comparison with the values obtained in the reference test discussed in section 10.1.3.

### 10.2.3 Freezing and thawing

This test consists of performing the following freeze-thaw cycle, as defined in the UNE-EN 494:1995 standard, test 7.4.1:

- Freezing in a -15°C freezer for 3 hours.
- Immersion in room temperature water for 3 hours.

From the results of the flexural strength test, it was observed that there was no decrease in the flexural strength, in comparison with the values obtained in the reference test discussed in section 10.1.3.

In no case was there any rupture of the panels tested during the freeze-thaw cycles.

<sup>(11)</sup> UNE-EN 494:1995: Fiber-cement profiled sheets and fittings. Product specification and test methods

NOELIA REDONDO JIMÉNEZ  
C/ Padre Llanos, 2 - 5ª B  
28053 MADRID  
Teléf. 647 731 429  
INTÉRPRETE JURADO INGLÉS

### 10.3 System serviceability test

#### 10.3.1 Pressure and suction tests on the mounting points

This is a test carried out according to an internal procedure at the DIT laboratory to determine resistance to wind suction for the ventilated façade fixing system.

In carrying out this test, the polyurethane sealant described in section 3.5 was not used.

The following breaking load values were obtained:

	Suction	Pressure
Dimensions (mm)	1000 x 405 x 19.5	
Average breaking load (kN)	1.85	9.22
Approximate resistance of the fastener (kN)	0.45	2.30
Equivalent wind pressure * (kN/m <sup>2</sup> )	4.25	22.70

\* Without safety coefficient or load increase.

#### 10.3.2 Resistance to soft body impact

This test was carried out in accordance with the specifications established in the draft EOTA Guideline, section 5.4.4.1 "Resistance to soft body impact".

The following results were obtained:

Impact energy (J)	1000 x 405 x 19.5 panel
10 J	No visible damage
3 x 60 J	No visible damage
300 J	Breakage without falling

#### 10.3.3 Resistance to hard body impact

This test was carried out in accordance with the specifications established in the draft EOTA Guideline, section 5.4.4.2 "Resistance to hard body impact".

The following results were obtained:

Impact energy (J)	1000 x 405 x 19.5 panel
1 J	No visible damage
3 J	Breakage without falling
10 J	Breakage without falling

#### 10.3.4 Heat-rain thermal shock test

This test was carried out in accordance with the specifications established in the draft EOTA Guideline, section 5.4.7 "Hygrothermal behavior".

The test is carried out in two stages, the first being heat-rain and the second heat-ice.

It was verified that after the two stages, there are no visible defects in the panels or permanent deformations in the fixings, the profiles of the sub-structure or the fasteners.

#### 10.3.5 Sub-structure tests. Vertical profile

##### a) Resistance to wind thrust

A load acting in accordance with wind pressure was applied to the center section of an aluminum profile with a T-section, supported on its two arms with a distance of 1.5 meters between points of support.

Its load-deformation curve was obtained, confirming that the profile, operating elastically, supports a load of 1.60 kN, total load, equivalent to a uniform excess wind pressure load of 4 kN/m<sup>2</sup> for a distance between profiles of 1.0 m and a distance between points of support of 1.1 m, without a safety coefficient or load increase.

##### b) Resistance to wind suction

A load acting in accordance with wind suction was applied to the center section of an aluminum profile with a  $\perp$ -section, supported on its arm with a distance of 1.5 meters between points of support.

Its load-deformation curve was obtained, confirming that the profile, operating elastically, supports a load of 0.60 kN, total load, equivalent to a uniform excess wind pressure load of 1.5 kN/m<sup>2</sup> for a distance between profiles of 1.0 m and a distance between points of support of 1.1 m, without a safety coefficient or load increase.

#### 10.3.6 Tensile strength of the mounting clamp flange

This test was carried out in accordance with the specifications established in the draft EOTA Guideline, section 5.4.2.3.1 "Resistance of grooved cladding elements".

The result was an average breaking load of 0.86 kN for the flange.

NOELIA REDONDO JIMÉNEZ  
C/ Padre Llanos, 2 - 5º B  
28053 MADRID  
Teléf. 647 731 429  
INTÉRPRETE JURADO INGLÉS

### 10.3.7 Vertical load test

This test was carried out in accordance with the specifications established in the draft EOTA Guideline, "Guideline for European Technical Approval of Kits for external wall claddings. Part 1: Ventilated cladding elements and associated fixing devices" (January 2006 edition), section 5.4.2.6.2 "Resistance of vertical load".

In order to perform the test, a ceramic panel 1,000 mm in length and 405 mm in width, with a thickness of 19.5 mm, was mounted, fixed to the aluminum sub-structure, which was in turn fixed to the test bench.

A flexometer was then placed in the center of the panel in order to measure vertical movements of the panel under a static load which corresponds to the weight of two cladding elements (31.2 kg.).

After 24 hours, no deformations or visible damage were observed in either the panel or fasteners.

## 10.4 System durability tests

### 10.4.1 Suction fatigue test

This is a test carried out according to an internal procedure at the DIT laboratory to determine resistance to fatigue caused by wind suction for the ventilated façade fixing system.

The tests were carried out by applying a load at a frequency of 0.5 Hz for 25,000 cycles.

Having completed the fatigue test, the initial static test for wind suction was carried out, with no significant decrease in the resistance of the mounting points

## 11. EVALUATION OF SERVICEABILITY

### 11.1 Compliance with national regulations

#### 11.1.1 SE – Structural safety

The FRONTEK PLUS ventilated façade cladding system with ceramic panels does not contribute to the stability of the structure. Consequently, the Basic Structural Safety Requirements are not applicable.

However, it should be taken into consideration that the structural behavior of the ventilated façade must be such that it does not compromise compliance with the other Basic

Requirements, in particular those governing Safe Utilization and Occupancy, as indicated in the Building Standards Law: *Safe utilization so that the normal use of the building does not constitute a risk of accident for persons* (article 3.1.b.3), and *other functional aspects of the construction elements or systems which make satisfactory use of the building possible* (article 3.1.c.4).

The substrate for the ventilated façade system, normally made up of an enclosure wall, must be in compliance with the essential relevant structural safety requirements. The actions and stresses transferred to it by the ventilated façade system must be taken into consideration.

The joining between the system's sub-structure and the wall behind must be planned so that during the period of use, the maximum extreme stress or maximum durability values are not exceeded.

#### 11.1.2 SI – Safety in the event of fire

The composition of the enclosure, including the insulation, must comply with the CTE, Basic Safety Document in the Event of Fire (DB-SI), with regard to fire stability, as well as reaction to fire for the materials which make it up.

According to Commission Decision 96/603/EC, of October 4, 1996, fired clay products obtain a reaction to fire classification of A1 (no contribution to the fire) without requiring tests.

The cladding material complies with the requirements of CTE-DB-SI (SI-2, section 1.4), regarding exterior fire spread for the materials used for exterior façade cladding and the interior surfaces of the façade's ventilated chambers.

#### 11.1.3 SU – Safe use

The CTE does not specify requirements regarding safe use for ventilated façade systems. However, for the lower section of the building next to trafficable areas accessible to the public, an intermediate vertical profile must be put into place for 80, 90 and 100 cm panels.

#### 11.1.4 Health

The entire enclosure solution must guarantee the minimum level of impermeability required for the building to which it is added, as described in the CTE-DB-HS code, with the aim of meeting the basic requirement for protection against moisture (HS 1).

NOELIA REDONDO JIMÉNEZ  
C/ Padre Llanos, 2 - 5º B  
28053 MADRID  
Teléf. 647 731 429  
INTÉRPRETE JURADO INGLÉS

As the system is described in the Technical Report, the ventilated air chamber may be considered a “very highly resistant barrier to filtration” (B3), as described in the CTE-DB-HS code, HS 1, section 2.3.2, provided that:

- The dimensions of the air chamber and joints are respected, as well as the number of ventilation openings described in section 7 of the Technical Report.
- The insulating material must be non-hydrophilic and be located between the air chamber and the supporting element.
- A system for collection and removal of the water filtering into the chamber must be located in the lower part of the chamber and wherever it is blocked (as described in section 2.3.3.5 of the CTE-DB-HS code, HS-1).

In any event, when designing the façades, special attention must be paid to incorporating the windows and lighting elements, as well as a proper solution for unique points, exterior fixings, etc. in order to achieve an adequate level of watertightness at these points, preventing water from accumulating and filtering through.

Checking the moisture limits for surface and interstitial condensation must be carried out as established in section HE-1 (Limiting energy demand) of the CTE-DB-HE code (HE-1, section 3.2.3).

The system’s components, as stated by their manufacturer, do not contain or emit hazardous substances, according to national and European legislation.

#### 11.1.6 HR – Protection from noise

The entire enclosure solution, primarily the supporting wall and the insulation, must comply with the requirements of the CTE-DB-HR code with regard to protection from noise.

The construction solution for the spot where the façade meets the vertical separation elements will be studied in order to avoid the transfer of noise along the edges.

#### 11.1.5 HE – Saving energy

The entire construction solution for the enclosure must meet the requirements of the CTE, Basic Document on Saving Energy (DB-HE) with regard to hygrothermal behavior.

For the system, as it is described in the Technical Report, as described in Appendix E of the CTE-DB-HE code, for the purposes of calculating thermal transmittance, the air chamber shall be considered a “highly ventilated air chamber” and the total thermal resistance of the enclosure is obtained by disregarding the thermal resistance of the air chamber and other layers between the air chamber and exterior atmosphere, and including the exterior surface resistance corresponding to still air, equal to the interior surface resistance of the same element (HE-1, Appendix E).

### 11.2 Use of the product. Installation and conditions for evaluation

#### 11.2.1 Installation

Prior to installing the system, the type and condition of the substrate must be verified in order to define the type and number of fasteners. The type of fastener must be suitable for the substrate. It may be necessary for the installer to replace the fasteners initially defined in the plans, which must be authorized by the site manager.

When working at unique points such as sills, lintels, jambs, parapets, etc., their watertightness and waterproofing must be taken into account, if necessary, as well as proper water removal, preventing it from accumulating.

The recommendations for handling the panels given under section 6 in the Technical Report shall be followed. Additionally, protective gloves must be used when handling the panels.

#### 11.2.2 Evaluation conditions

The aspects relating to calculations included under section 9 of the present document refer to the scope of application of the Basic Document for Structural Safety relative to Actions on Buildings in the CTE (DB-SE-AE).

For those cases which go beyond the scope of application of the aforementioned Basic Document, or when the action of the wind is expected to be greater than considered in the CTE-DB-SE-AE code, it will be necessary to perform a specific study to determine the action of the wind.





### 11.3 Waste management

The stipulations of Royal Decree 105/2008, governing the Production and Management of Construction and Demolition Waste, shall be followed, as well as any applicable autonomous community and local regulations.

### 11.4 Maintenance and conditions of service

According to the durability tests carried out and site visits, it is believed that the system behaves satisfactorily in accordance with requirements relative to durability, provided that the façade, installed as described in the present document, is subject to suitable use and maintenance, as established in the CTE.

The manufacturer's recommendations will be followed to clean the panels. The method of cleaning is similar to that of normal ceramic panels.

## 12. CONCLUSIONS

Having verified that the manufacturing process for the FRONTEK ceramic panels by VENATTO DESIGN, S.L. includes quality control which consists of self-inspection, by means of which the manufacturer verifies the suitability of the raw materials, manufacturing process and product control.

In consideration of the fact that the manufacturing process and installation have been sufficiently verified in practice and by the results obtained during testing, the suitability of using the system proposed by the manufacturer receives a favorable evaluation, with the remarks made by the Committee of Experts in this DIT.

#### REPRESENTATIVES:

Dr. Tomás Amat Rueda  
Civil Engineer

Rosa Senent  
Architect

## 12. REMARKS OF THE COMMITTEE OF EXPERTS

The main remarks of the Committee of Experts, at a meeting held at the Eduardo Torroja Institute for Construction Science on April 21, 2009,<sup>(12)</sup> were as follows:

- It is recommended that GRECO GRES INTERNACIONAL, S.L. provide consulting services for design and execution of gaps and unique points.

<sup>(12)</sup> The Committee of Experts was made up of representatives from the following organizations and bodies:

- ACCIONA INFRAESTRUCTURAS, S.A. ENGINEERING MGR.
- Association of Independent Quality Control and Technical Control Companies (aeccti).
- Spanish High Council of Architectural Schools (CSCAE).
- Control Técnico y Prevención de Riesgos (CPV).
- DRAGADOS, S.A.
- University School of Technical Architecture of Madrid (EUATM-UPM).
- FCC Construcción, S.A.
- FERROVIAL-AGROMAN, S.A.
- Instituto Técnico de Inspección y Control, S.A. (INTEINCO, S.A.).
- Instituto Técnico de Materiales y Construcciones, S.A. (INTEMAC, S.A.).
- Army Engineers Laboratory.
- Ministry of Housing.
- QUALIBÉRICA, S.A.
- SOCOTEC Iberia, S.A.
- SGS Tecnos, S.A.
- Polytechnic University of Madrid (UPM).
- Eduardo Torroja Institute for Construction Science

NOELIA REDONDO JIMÉNEZ  
C/ Padre Llanos, 2 - 5º B  
28053 MADRID  
Teléf. 647 731 429  
INTÉRPRETE JURADO INGLÉS

- It shall be verified that the type of fastener defined in the plans is suitable for the type and condition of the substrate.
- If there is insulation in place, it shall be verified that this is uninterrupted.
- Given that the profiles are not continuous, it is recommended that care be taken to ensure that the layout of the sections is uninterrupted.
- It is recommended that it be verified that no panel is fixed to two different vertical profiles.
- In atmospheres with a corrosivity classification of C4 or C5, according to ISO 9223,<sup>(13)</sup> it is recommended that AISI-316 stainless steel be used for the screws and clamps.
- Ancillary metal elements in contact with the system must not create corrosion problems.
- A reminder is given that ventilated façade cladding systems do not guarantee the watertightness of the enclosure with just the exterior cladding. In any event, it is recommended that the behavior of the complete enclosure be studied as a whole, as described in the CTE, Basic Document for Health (DB-HS) with regard to protection against damp (HS-1).
- The joints of the cladding shall take the building's expansion joints into account.
- It is recommended that a copy of the present Technical Suitability Document be incorporated into the Building Record.

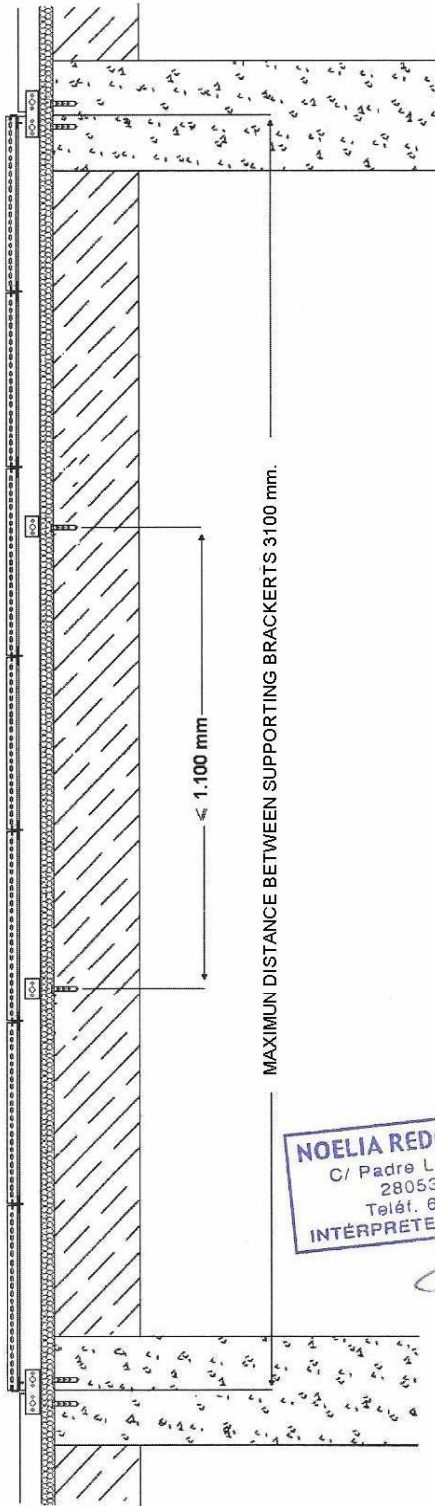
<sup>13</sup> Categories of corrosivity:

C4 = High (exterior: non-marine industrial and urban marine).

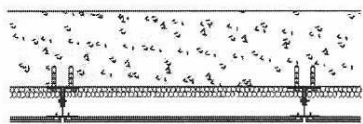
C5 = Very high (exterior: very damp industrial or with high salinity levels).

ISO 9223 Corrosion of metals and alloys – Corrosivity of atmospheres – Classification.

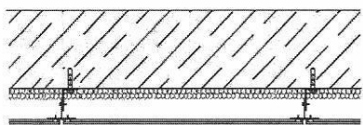
**NOELIA REDONDO JIMÉNEZ**  
 C/ Padre Llanos, 2 - 5º B  
 28053 MADRID  
 Teléf. 647 731 429  
 INTÉRPRETE JURADO INGLÉS



**NOELIA REDONDO JIMÉNEZ**  
 C/ Padre Llanos, 2 - 5º B  
 28053 MADRID  
 Teléf. 647 731 429  
 INTÉRPRETE JURADO INGLÉS



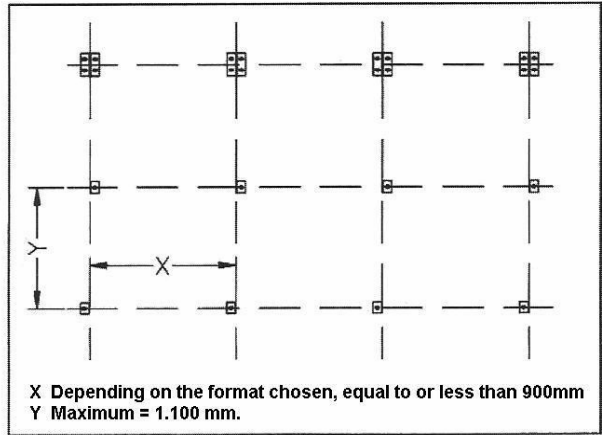
FIXING THE SUPPORT BRACKETS TO THE SLAB



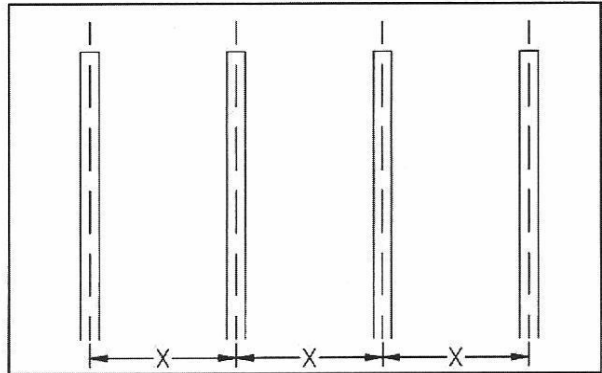
FIXING THE RETAINING BRACKETS TO THE WALL

**Figure 1. VERTICAL AND HORIZONTAL SECTIONS**

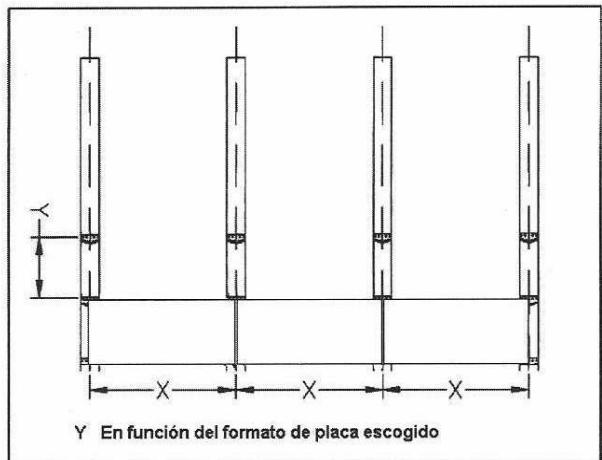
**1. INSTALLATION OF SEPARATORS**



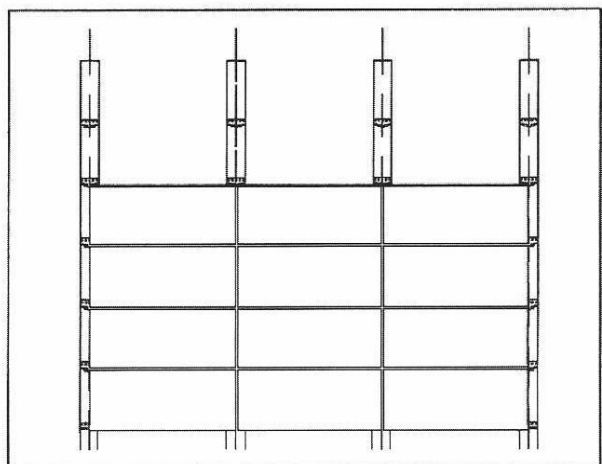
**2. INSTALLATION OF VERTICAL PROFILES**



**3. INSTALLATION OF INITIAL CLAMPS AND PANELS**



**4. SUCESIVE INSTALLATION OF CERAMIC PANELS**



**Figure 2. STAGES OF ASSEMBLY.**

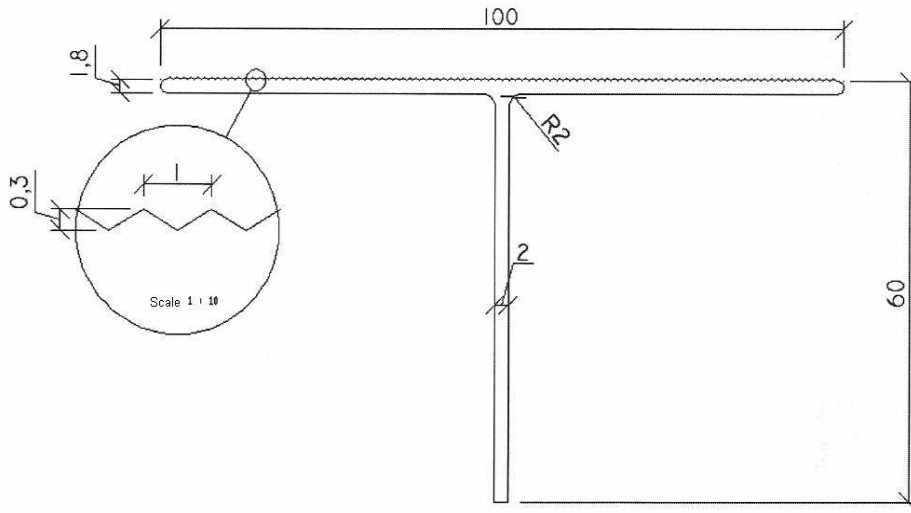
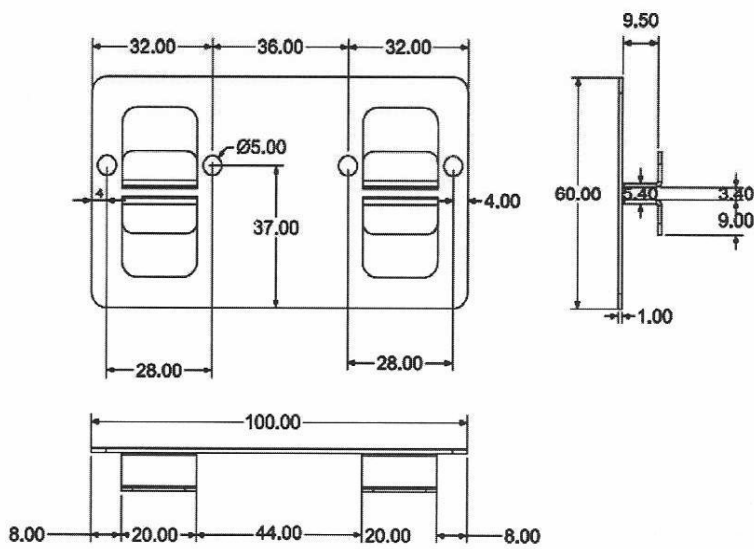


Figure 3. VERTICAL PROFILE.

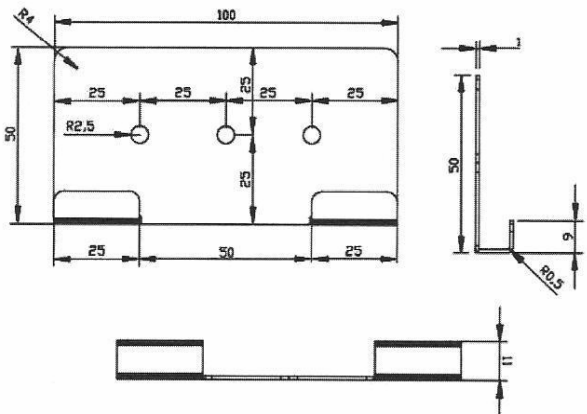
INTERMEDIATE CLAMP



**NOELIA REDONDO JIMÉNEZ**  
 C/ Padre Llanos, 2 - 5º B  
 28053 MADRID  
 Teléf. 647 731 429  
 INTÉRPRETE JURADO INGLÉS

*Noelia Redondo*

END / TOP CLAMPS



SPECIAL CLAMP FOR TURNS

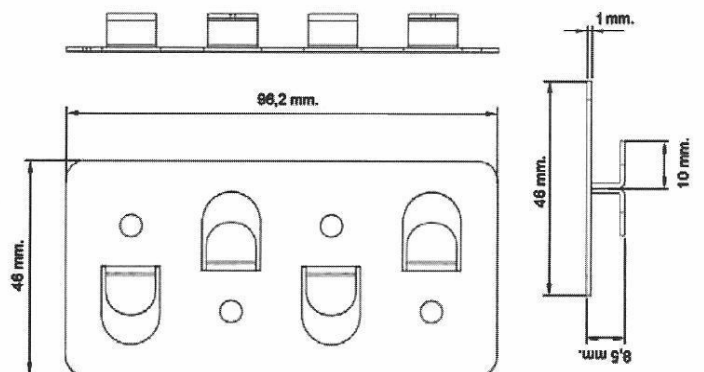
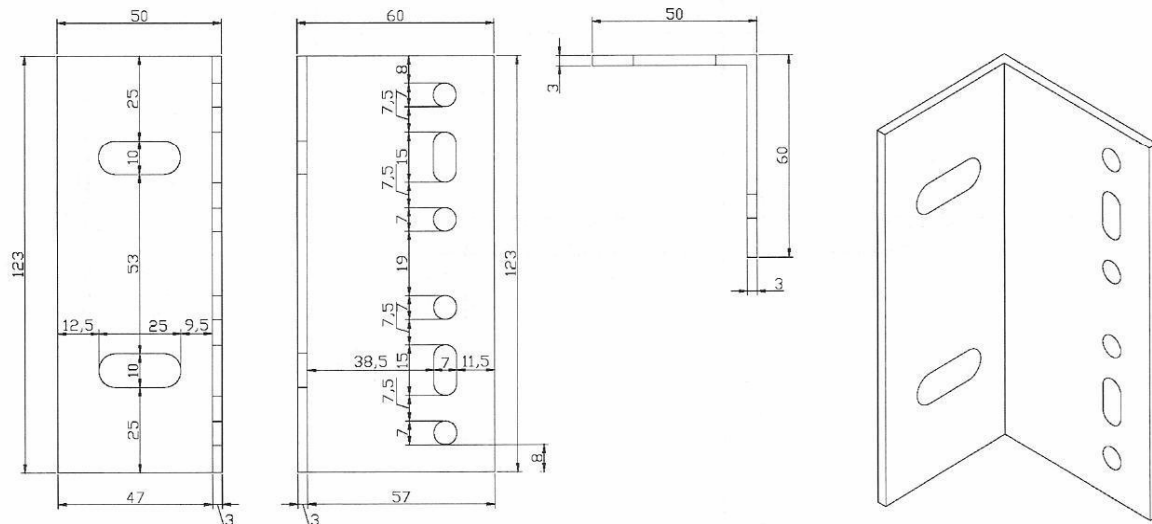
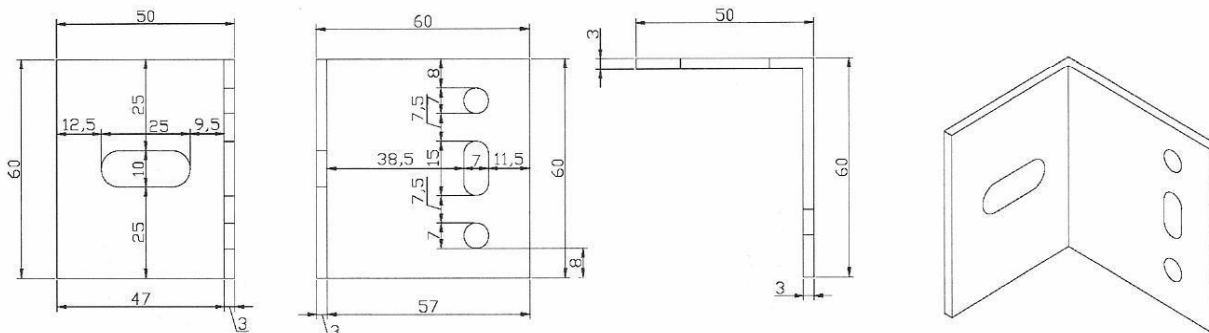


Figure 4. FIXING CLAMPS.

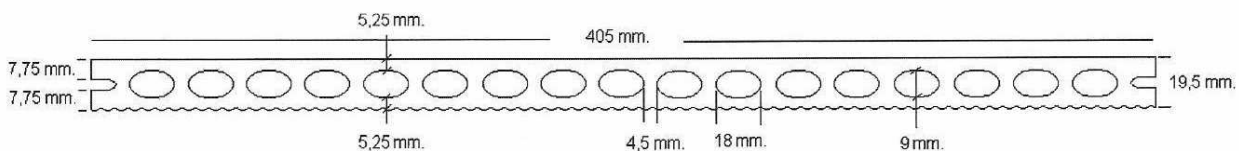
**ECI 60 SUPPORTING BRACKET**



**ECI 60 RETAINING BRACKETS**

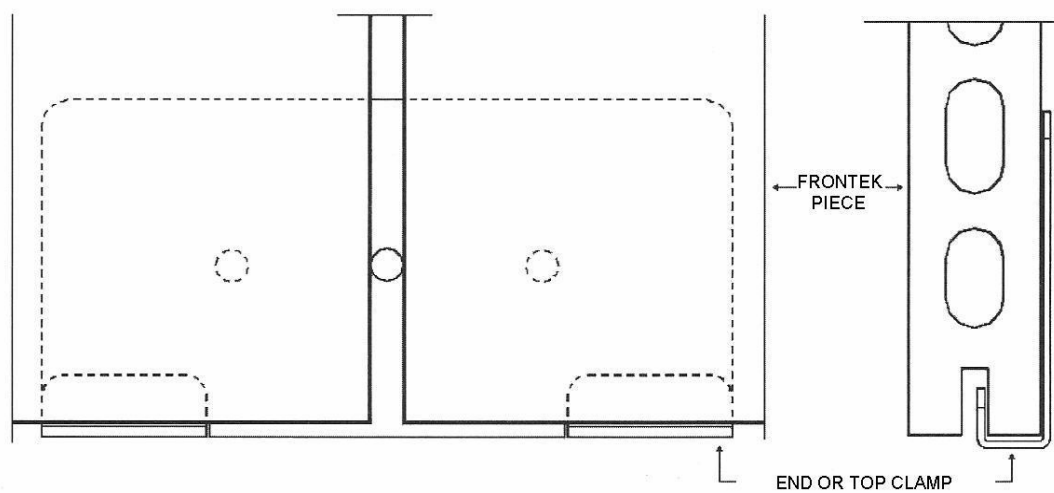
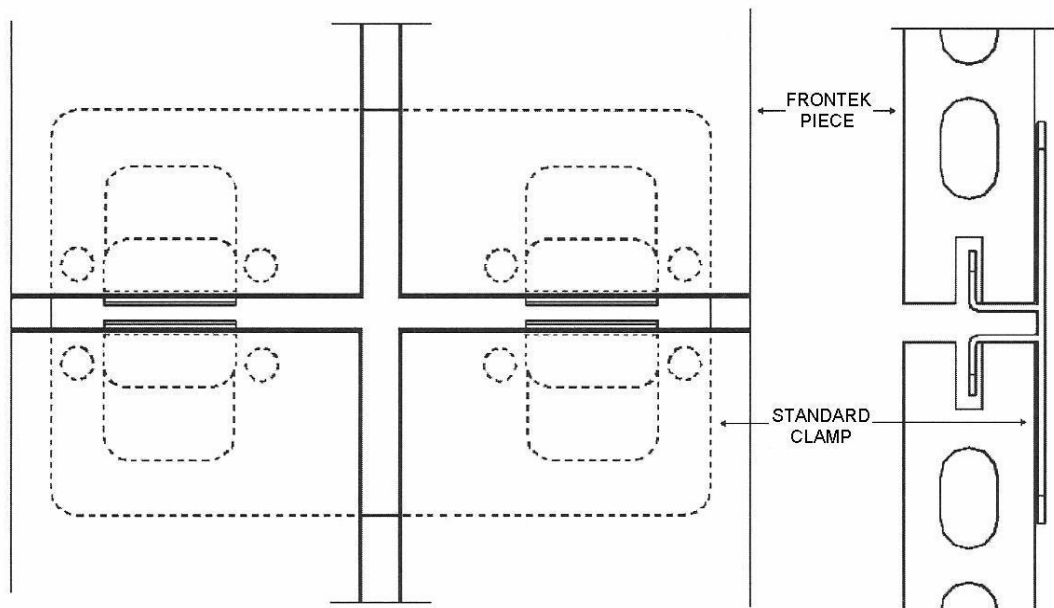


**Figure 5. SUPPORTING AND RETAINING BRACKETS.**



**Figure 6. PANEL.**

**NOELIA REDONDO JIMÉNEZ**  
 C/ Padre Llanos, 2 - 5º B  
 28053 MADRID  
 Teléf. 647 731 429  
 INTÉRPRETE JURADO INGLÉS



- Notes:**
- The construction details shown in the figures are intended to server only as a guideline and must be defined for each project.
  - The construction details defined in the figures refer to the fixing system for a ventilated façade and cannot be used as evidence of compliance with other basic requirements of the C.T.E.

**Figure 7. DETAIL OF THE FIXING SYSTEM**

NOELIA REDONDO JIMÉNEZ  
 C/ Padre Llanos, 2 - 5º B  
 28053 MADRID  
 Teléf. 647 731 429  
 INTÉRPRETE JURADO INGLÉS

*Noelia Redondo Jimenez*

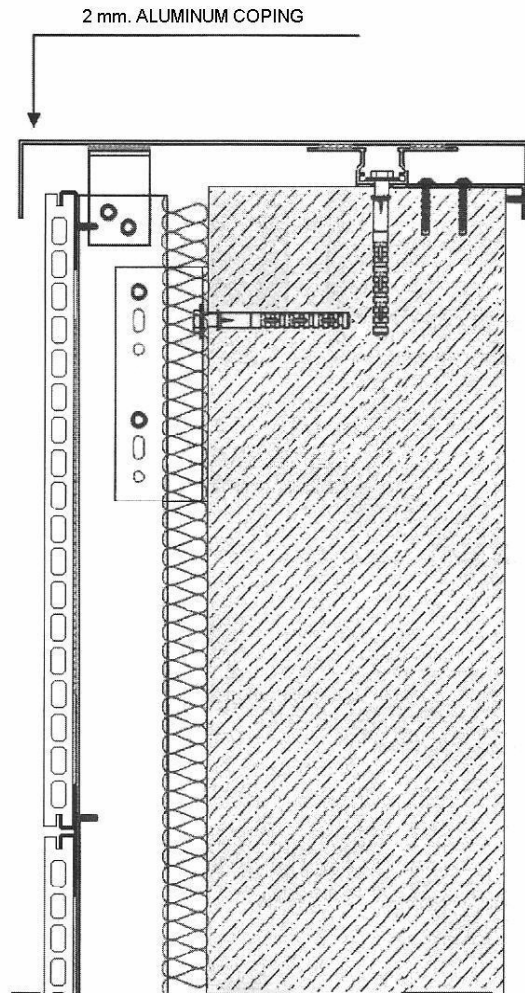


Figure 8. METAL COPING.

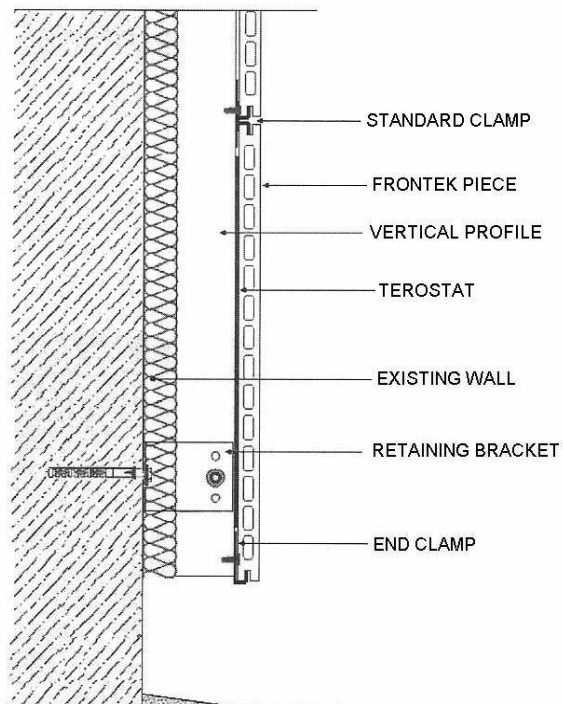


Figure 9. END.

NOELIA REDONDO JIMÉNEZ  
 C/ Padre Llanos, 2 - 5ª B  
 28053 MADRID  
 Teléf. 647 731 429  
 INTÉRPRETE JURADO INGLÉS

*Noelia Redondo Jimenez*

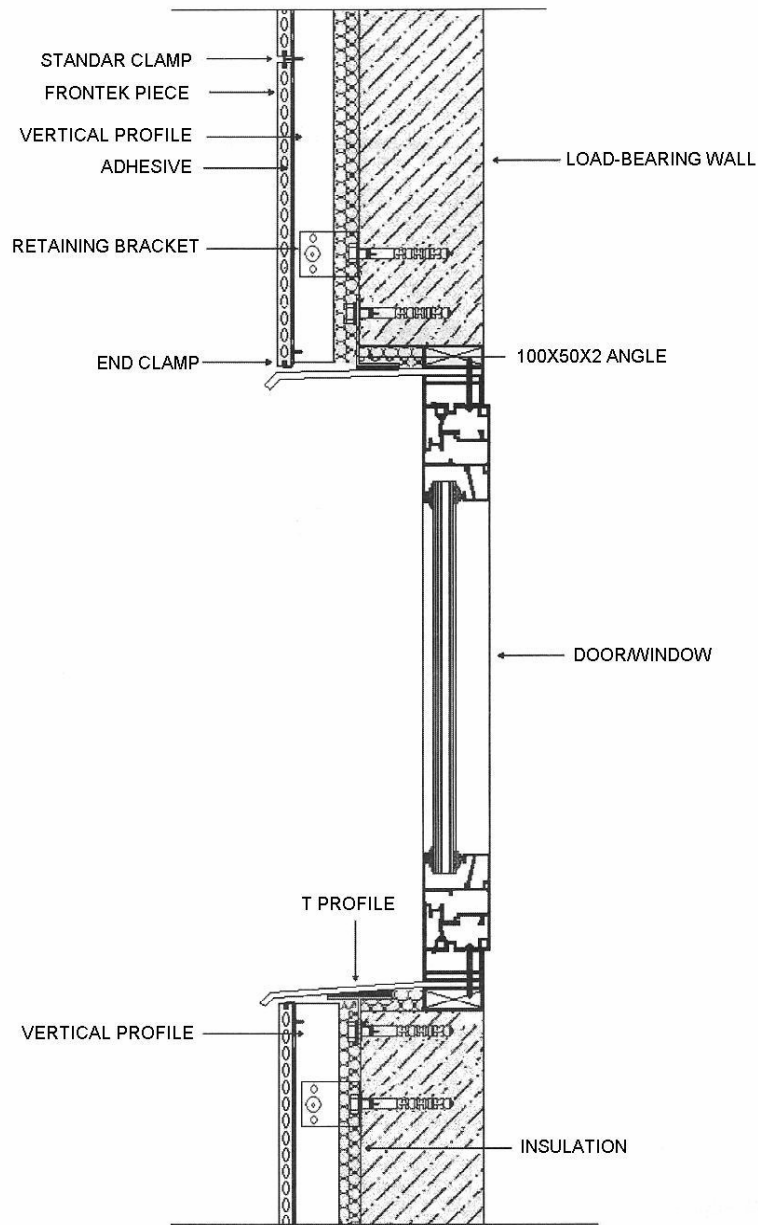
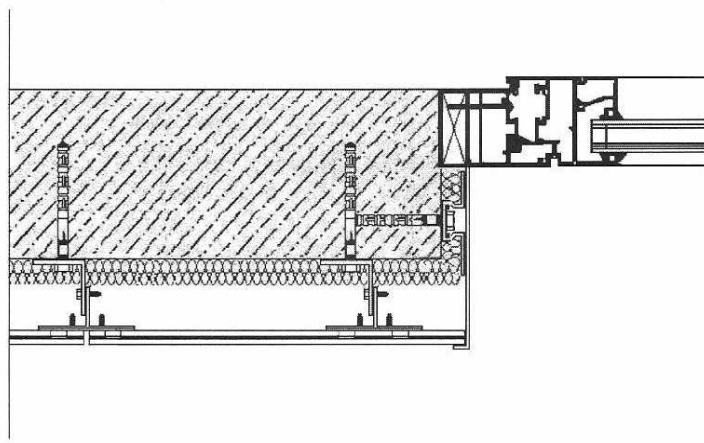


Figure 10. VERTICAL SECTION, METAL ENCLOSURE.



NOELIA REDONDO JIMÉNEZ  
 C/ Padre Llanos, 2 - 5º B  
 28053 MADRID  
 Teléf. 647 731 429  
 INTÉRPRETE JURADO INGLÉS

*Noelia Jiménez*

Figure 11. HORIZONTAL SECTION, METAL ENCLOSURE.



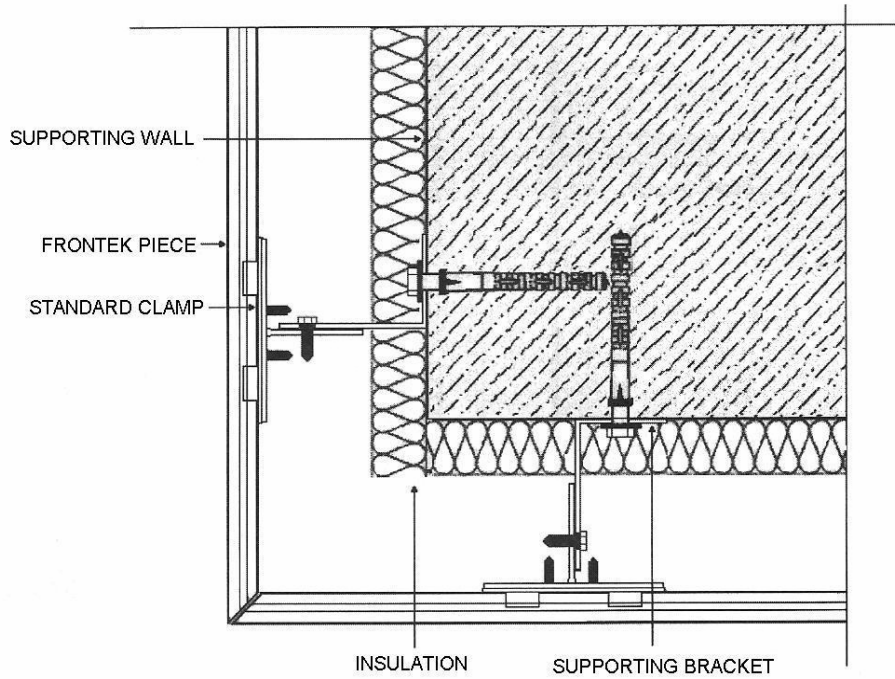


Figure 12. OUTSIDE CORNER.

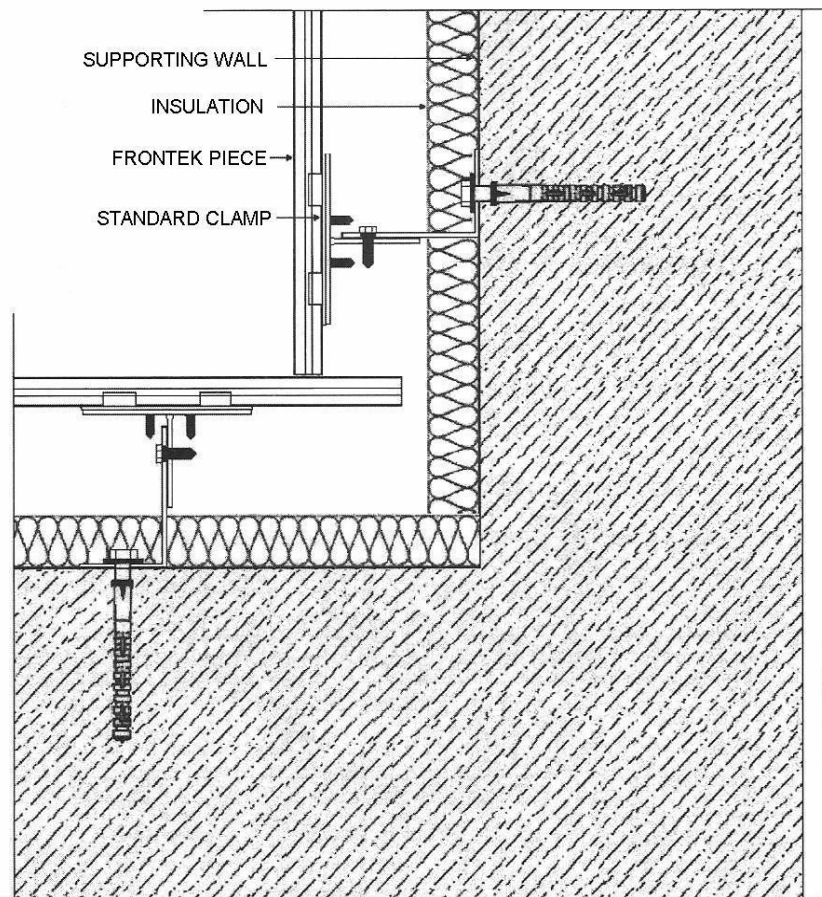


Figure 13. INSIDE CORNER.

NOELIA REDONDO JIMÉNEZ  
 C/ Padre Llanos, 2 - 5ª B  
 28053 MADRID  
 Teléf. 647 731 429  
 INTÉRPRETE JURADO INGLÉS

*Noelia Jimenez*

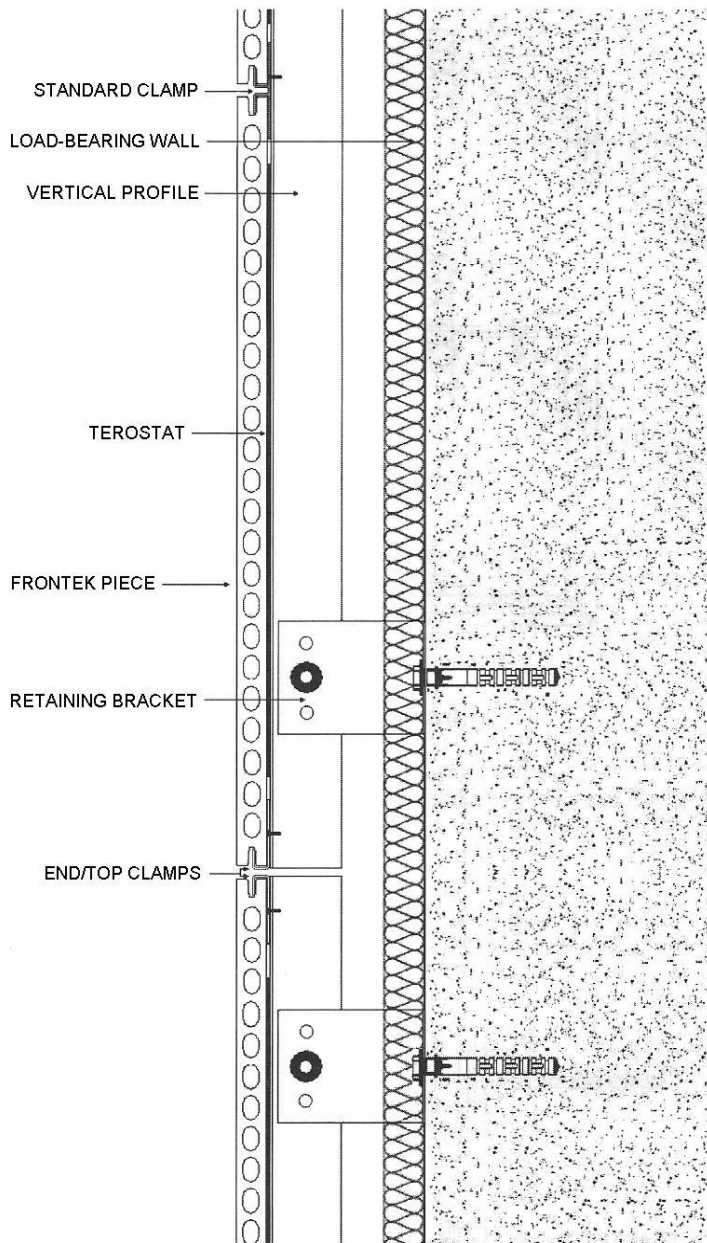


Figure 14. VERTICAL EXPANSION JOINT.

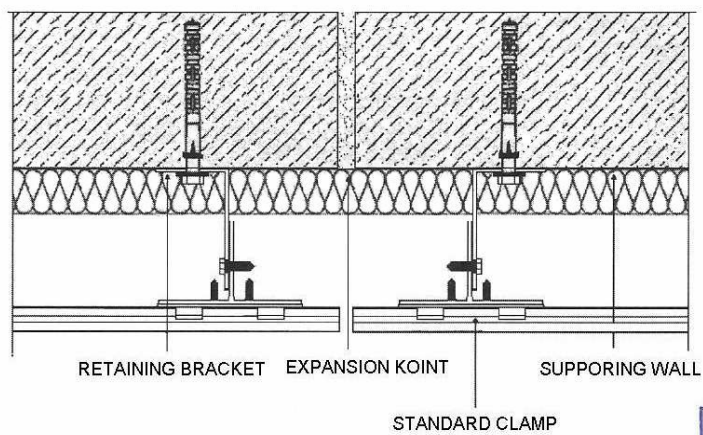


Figure 15. HORIZONTAL EXPANSION JOINT.

I, Noelia Redondo Jiménez, sworn translator authorized by the Spanish Ministry of Foreign Affairs to translate official documents into and out of the English language, do hereby certify that this is a true and faithful English translation of a document submitted to me in Spanish.

Witness my hand and seal this twenty-sixth day of February.

Doña Noelia Redondo Jiménez, intérprete Jurado de Inglés, certifica que la que antecede es una traducción fiel y completa al inglés de un documento redactado en español.

En Madrid, a 26 de Febrero de 2010.

**NOELIA REDONDO JIMÉNEZ**  
 C/ Padre Llanos, 2 - 5º B  
 28053 MADRID  
 Teléf. 647 731 429  
 INTÉRPRETE JURADO INGLÉS

*Noelia Redondo Jiménez*

# frontek

Technological ceramics in ventilated façade

[www.grecogres.com](http://www.grecogres.com)

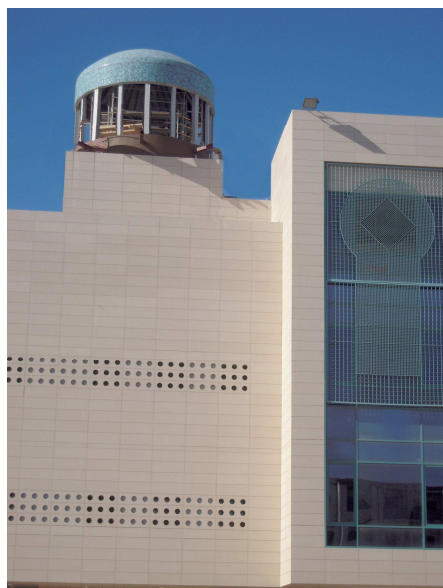
## PROYEC OF FRONTEK IN ARGELIA.

### LOCATION

Coference Hall and Exhibitions  
of Oran.

37.000 m<sup>2</sup> Sonora

Oran (Argelia)



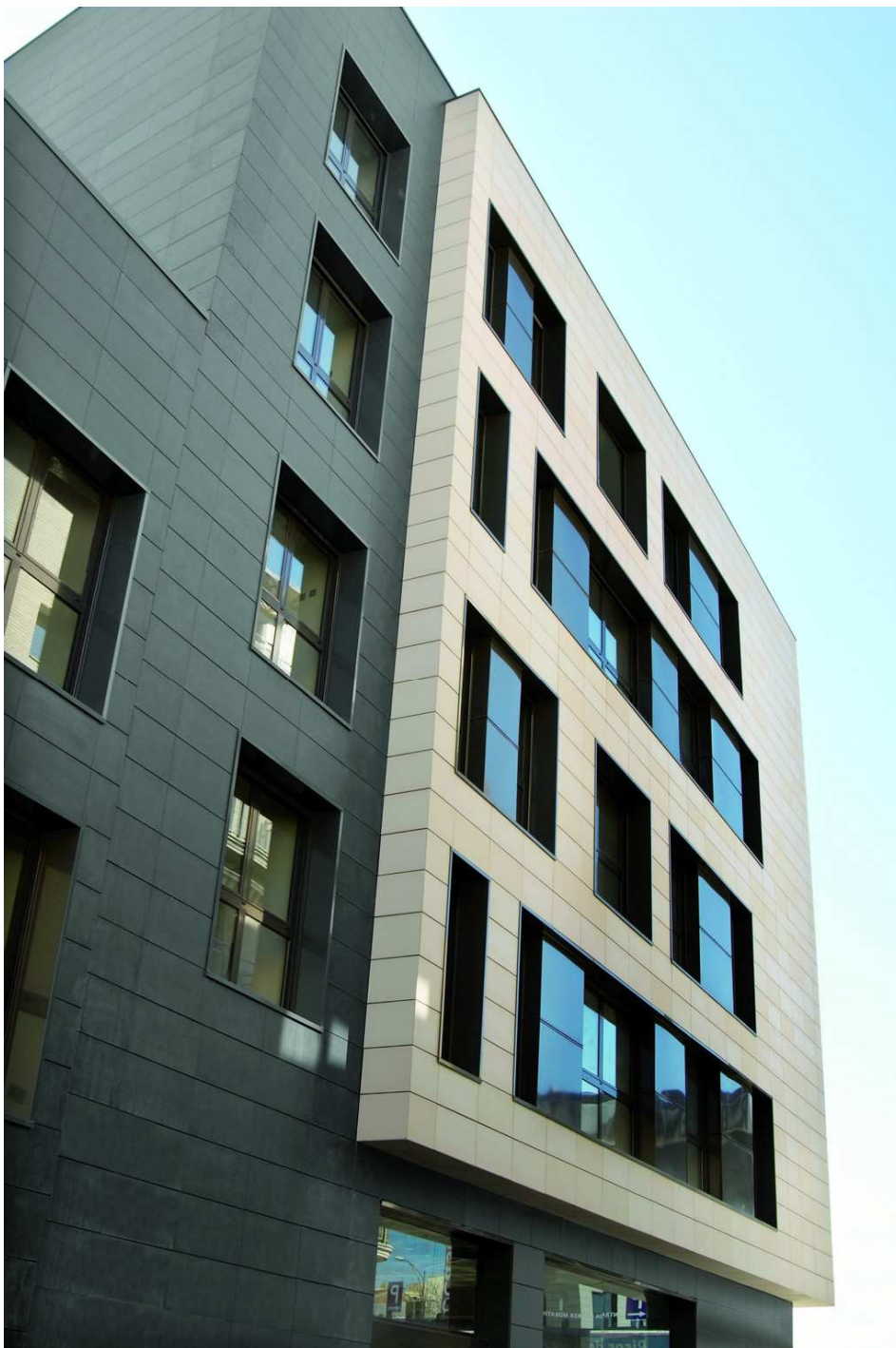
## PROYEC OF FRONTEK IN THE COMMUNITY OF CATALUNYA

### LOCATION

Housings in Sabadell

640 m<sup>2</sup> Iceberg - Azabache

Rda. Ponent, 80 to 126  
Sabadell (Barcelona)



## PROYECT OF FRONTEK IN THE COMMUNITY OF MADRID.

### LOCATION

Students' Residence CEU

650 m<sup>2</sup> Canyon/Azabache 40 x 80 Plus

Avda. Montepincipe - Boadilla del Monte (Madrid)



**PROYECT OF FRONTEK IN THE COMMUNITY OF MADRID.**

**LOCATION**

Supercor Pinto (El Corte Ingles)

700 m<sup>2</sup> - Iceberg

Pza. de la Asunción, 2 (Pinto)

